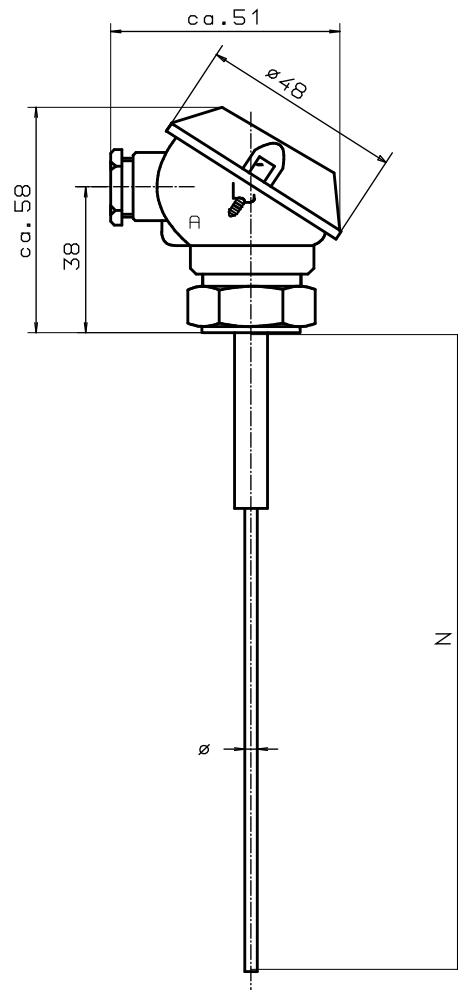

Sheath thermocouple with connection head type MA(J)

| | |
|----------------------------|---|
| Thermopair | Fe-CuNi NiCr-Ni |
| Working-temperature | Fe-CuNi up to 400°C NiCr-Ni up to 600°C |
| Version | Standard version hot junction isolated from the outer sheath welded |
| Outer sheath | Stainless steel W-No. 1.4541 (800 °C) Inconel W-No. 2.4816 (1200 °C) |
| Connection head | Form MA(J) of Aluminium light alloy with Pg 9 / M16x1,5 Cable-screw |
| Connecting | Datasheet 19.20 |
| Nominal length | 500 mm included in the list price |

Version Outer sheath stainless steel W.No.1.4541

| Element Ø in mm | Order-No. 1 x Fe-CuNi | Add. price 100mmNL | Order-No. 2 x Fe-CuNi | Add. price 100mmNL | Order-No.. 1 x Ni-CrNi | Add. price 100mmNL | Order-No. 2 x Ni-CrNi | Add. price 100mmNL |
|--------------------|--------------------------|-----------------------|--------------------------|-----------------------|---------------------------|-----------------------|--------------------------|-----------------------|
| 1,5 | 1.60.04.11 | 1.60.04.01 | 1.60.04.12 | 1.60.04.10 | 2.60.04.11 | 2.60.04.01 | 2.60.04.12 | 2.60.04.10 |
| 3,0 | 1.60.04.21 | 1.60.04.02 | 1.60.04.22 | 1.60.04.20 | 2.60.04.21 | 2.60.04.02 | 2.60.04.22 | 2.60.04.20 |
| 4,5 | 1.60.04.31 | 1.60.04.03 | 1.60.04.32 | 1.60.04.30 | 2.60.04.31 | 2.60.04.03 | 2.60.04.32 | 2.60.04.30 |
| 6,0 | 1.60.04.41 | 1.60.04.04 | 1.60.04.42 | 1.60.04.40 | 2.60.04.41 | 2.60.04.04 | 2.60.04.42 | 2.60.04.40 |

Version Outer sheath Inconell W –No. 2.4816

| Element Ø in mm | Order-No. 1 x Fe-CuNi | Add. price 100mmNL | Order-No. 2 x Fe-CuNi | Add. price 100mmNL | Order-No. 1 x Ni-CrNi | Add. price 100mmNL | Order-No. 2 x Ni-CrNi | Add. price 100mmNL |
|--------------------|--------------------------|-----------------------|--------------------------|-----------------------|--------------------------|-----------------------|--------------------------|-----------------------|
| 1,5 | 1.60.05.11 | 1.60.05.01 | 1.60.05.12 | 1.60.05.10 | 2.60.05.11 | 2.60.05.01 | 2.60.05.12 | 2.60.05.10 |
| 3,0 | 1.60.05.21 | 1.60.05.02 | 1.60.05.22 | 1.60.05.20 | 2.60.05.21 | 2.60.05.02 | 2.60.05.22 | 2.60.05.20 |
| 4,5 | 1.60.05.31 | 1.60.05.03 | 1.60.05.32 | 1.60.05.30 | 2.60.05.31 | 2.60.05.03 | 2.60.05.32 | 2.60.05.30 |
| 6,0 | 1.60.05.41 | 1.60.05.04 | 1.60.05.42 | 1.60.05.40 | 2.60.05.41 | 2.60.05.04 | 2.60.05.42 | 2.60.05.40 |

Standard version : Probe tip isolated from the outer sheath welded
Spezial version : Probe tip with the outer sheath welded